

## ARTICLE 7.

### SIGNS

Sec. 7.1.	Purpose and intent.....	7-1
Sec. 7.2.	Sign permits and administration. ....	7-1
	1. Sign permit required. ....	7-1
	2. Application for a sign permit. ....	7-1
	3. Sign permit review criteria.....	7-2
	4. Appeal of sign permit denial or approval with conditions.....	7-3
	5. Waivers .....	7-3
	6. Permits to be Withheld – Illegal or Prohibited Signs on Parcel. ....	7-3
Sec. 7.3.	Enforcement.....	7-3
	1. Discontinued establishments; removal of signs.....	7-3
	2. Illegal signs.....	7-3
Sec. 7.4.	Exempt signs.....	7-3
Sec. 7.5.	Prohibited signs.....	7-8
Sec. 7.6.	Measurement of sign area and height. ....	7-10
	1. Sign surface area.....	7-10
	2. Sign support.....	7-10
	3. Back-to-back (double-faced) signs.....	7-10
	4. Three-dimensional signs.....	7-10
	5. Wall signs.....	7-10
	6. Sign height.....	7-11
	7. Approved sign wall area .....	7-11
Sec. 7.7.	Sign design.....	7-11
	1. Design compatibility.....	7-11
	2. Color.....	7-12
	3. Materials.....	7-12
	4. Legibility.....	7-12
	5. Sign illumination.....	7-13
Sec. 7.8.	Sign installation and maintenance. ....	7-13
	1. Installation.....	7-13
	2. Maintenance.....	7-13
Sec. 7.9.	Standards for specific types of signs.....	7-14
	1. Awning signs.....	7-14
	2. Banners .....	7-14
	3. Canopy signs.....	7-15
	4. Electronic Message Center Signs.....	7-16
	5. Freestanding signs.....	7-16
	6. Individual Business/Use Signs.....	7-16
	7. Off-premises signs .....	7-17
	8. Projecting signs.....	7-17
	9. Time and/or temperature signs.....	7-17
	10. Wall signs.....	7-18
	11. Window signs.....	7-18

Sec. 7.10.	Sign standards by zoning district.....	7-19
1.	Residential and agricultural signs.....	7-19
2.	Business and commercial signs.....	7-20

## **SIGNS**

### **Sec. 7.1. Purpose and intent.**

The regulations in this Article are intended to coordinate the use, placement, physical dimensions and design of all signs within the Town. The purpose of these regulations is to:

1. Recognize that signs are a necessary means of visual communication for the convenience of the public and provide flexibility within the sign review/approval process to allow for unique circumstances and creativity.
2. Recognize and ensure the right of those concerned to identify businesses, services and other activities by the use of signs, and limit signs to those which are accessory and incidental to the use on the premises where such signs are located.
3. Provide a reasonable balance between the right of an individual to identify his or her business and the right of the public to be protected against the visual discord resulting from the unrestricted proliferation of signs and similar devices.
4. Protect the public from damage or injury caused by signs that are poorly designed or maintained and from distractions or hazards to pedestrians or motorists caused by the indiscriminate placement or use of signs.
5. Ensure that signs are well-designed and contribute in a positive way to the Town's visual environment, express local character and help develop a distinctive image for the Town.
6. Encourage signs that are responsive to the aesthetics and character of their particular location, adjacent buildings and uses and the surrounding neighborhood; and ensure that signs are compatible and integrated with the building's architectural design and with other signs on the property.
7. Ensure that signs are appropriate for the type of street on which they are located.
8. Bring nonconforming signs into compliance with these regulations.

### **Sec. 7.2. Sign permits and administration.**

1. Sign permit required. To ensure compliance with the regulations of this Article, a sign permit shall be required in order to erect, move, alter, reconstruct or repair any permanent or temporary sign, except signs that are exempt from permits in compliance with Section 7.4. In multiple tenant buildings, a separate permit shall be required for each business entity's signs. Separate building and electrical permits may be required for signs and will be determined on a case-by-case basis. Changing or replacing the copy on an existing lawful sign shall not require a permit, provided that the copy change does not change the nature of the sign or render the sign in violation of this Article.
2. Application for a sign permit.
  - a. Sign permit application requirements. Applications for sign permits shall be made in writing on forms furnished by Town staff. The application shall contain:

- (b) The location by street number and the legal description of the proposed sign structure;
  - (c) Names and addresses of the owner, sign contractor and erectors;
  - (d) Legible site plans which include the specific location of the sign and setbacks to adjacent property lines, buildings, and all existing and proposed signs on the property;
  - (e) A detailed drawing indicating the dimensions, materials and colors of the proposed sign structure. A certification by a structural engineer may be required by the Town staff for a freestanding or projecting sign;
  - (f) A graphic drawing or photograph of the sign copy;
  - (g) A description of the lighting to be used, if applicable;
  - (h) Proof of public liability insurance covering freestanding signs and projecting wall signs;
  - (i) If the sign is to be located off the premises advertised, a written lease or permission from the property owner of the site on which the sign will be located; and
  - (j) Sign permit fee and plan check fee as established by the current fee schedule. The applicant shall pay all costs billed by the Town relative to the review of the application.
- b. Sign permit application certification of completion. Within a reasonable time of the date of application submission, the Town staff shall either certify that the application is complete and in compliance of all submittal requirements or reject it as incomplete and notify the applicant in writing of any deficiencies.
- c. Staff review and approval. When the Town staff has determined the application to be complete, the Town staff shall review the sign permit in accordance with the established review criteria and has the authority to approve, approve with conditions or deny the sign permit. Upon the Town staff's approval of the sign permit, the sign permit and any building or electrical permits required for the sign shall be issued to the applicant.
3. Sign permit review criteria. The following review criteria will be used by the Town staff to evaluate all sign permit applications:
- a. The sign meets the requirements of this Article;
  - b. The sign conforms to the requirements of the building and electrical codes;
  - c. The sign conforms to the size, height, material and location requirements of this Code for the zoning district in which it is located;
  - d. The sign would not interfere with pedestrian or vehicular safety;
  - e. The sign would not detract from the character of an architecturally significant or historic structure;
  - f. The sign would not be located so as to have a negative impact on adjacent property;
  - g. The sign would not detract from the pedestrian quality of a street or area; and
  - h. The sign would not add to an over-proliferation of signs on a particular property or area.

4. Appeal of sign permit denial or approval with conditions. Any appeal of the Town staff's denial of a sign permit or approval with conditions shall be made to the Board of Adjustment as provided in this Code.
5. Waivers. Any request for an increase in the maximum allowable area for a sign, or for signs not expressly permitted in these regulations, must be approved through a waiver granted by the Board of Trustees.
6. Permits to be Withheld – Illegal or Prohibited Signs on Parcel. When a sign permit is requested for a parcel where illegal or prohibited signs exist, no sign permit shall be issued until all such signs are removed or brought into conformance with this Article. All existing and proposed signs on the property shall be shown on a sign permit application.

### **Sec. 7.3. Enforcement.**

1. Discontinued establishments; removal of signs. Whenever a business, industry, service or other use is discontinued, the signs pertaining to the use shall be removed or obscured by the person or entity owning or having possession of the property within ninety (90) days after the discontinuance of such use.
2. Illegal signs.
  - a. Penalties. Illegal signs shall be subject to Chapter 10 of the Municipal Code.
  - b. Removal of illegal signs in the public right-of-way. The Town may cause the removal of any sign within the public right-of-way or on property that is otherwise abandoned that has been placed there without first complying with the requirements of this Article.
  - c. Storage of removed signs. Signs removed in compliance with this Section shall be stored by the Town for thirty (30) days, during which they may be recovered by the owner only upon payment to the Town for costs of removal and storage. If not recovered within the thirty-day period, the signs and supporting structures shall be declared abandoned and title shall vest with the Town. The costs of removal and storage (up to thirty [30] days) may be billed to the owner. If not paid, the applicable costs may be imposed as a tax lien against the property.

### **Sec. 7.4. Exempt signs.**

The following types of signs are exempt from permit requirements of this Article and may be placed in any zoning district subject to the provisions of this Article. Such signs shall otherwise be in conformance with all applicable requirements contained in this Article. All such signs (except government signs) shall be located outside of a street right-of-way. Signs shall not interfere with traffic signs or the sight distance triangle at intersections (for information on the sight distance triangle, please refer to the Town of Frederick Design Standards and Construction Specifications). All other signs shall be allowed only with a building permit and upon proof of compliance with this Article.

1. Signs that are not visible beyond the boundaries of the lot or parcel upon which they are located and/or from any public thoroughfare or right-of-way shall be exempt from the provisions of this Article, except that such signs shall be subject to the safety regulations of the Uniform Building Code and the National Electrical Code.

2. Address. Nonilluminated signs not to exceed two (2) square feet in area which identify the address and/or occupants of a dwelling unit or of an establishment.
3. Building identification, historical markers. Nonilluminated signs constructed of metal or masonry which are permanently affixed to buildings or structures for the purpose of identifying the name of a building, date of erection or other historical information as approved by Town staff..
4. Bulletin board. Bulletin board signs not exceeding fifteen (15) square feet in gross surface area accessory to a church, school or public or nonprofit institution.
5. Construction. Temporary construction signs, provided that:
  - a. Signs shall have a maximum area of thirty-two (32) square feet each.
  - b. Only one (1) such sign oriented per street front per premises shall be erected. Any two (2) such signs located on the same premises shall be located at least one hundred (100) feet apart as measured by using a straight line.
  - c. Such signs shall not be illuminated.
  - d. Such signs shall only appear at the construction site.
  - e. Such signs shall be removed within seven (7) days after completion of the project.
  - f. Courtesy. Nonilluminated or indirectly illuminated signs which identify, as a courtesy to customers, items such as credit cards accepted, redemption stamps offered, menus or prices; limited to one (1) such sign for each use, not to exceed four (4) square feet per face or eight (8) square feet in total area. Such signs may be attached to the building as projecting or wall signs, suspended from a canopy or included as an integral part of a freestanding sign.
6. Decorations. Temporary decorations or displays, when such are clearly incidental to and are customarily and commonly associated with any national, state, local or religious holiday or celebration; provided that such signs shall be displayed for not more than sixty (60) days in any one (1) year; and may be of any type, number, area, height, location, illumination or animation.
7. Directional. On-premises directional and instructional signs not exceeding six (6) square feet in area apiece.
8. Doors. Signs affixed to door glass which identify the name and/or address of an establishment.
9. Farm products. Temporary farm product signs, provided that:
  - a. One (1) on-premises sign may be used. Said sign shall be located off the street right-of-way and at least ten (10) feet away from any side lot line. Such sign shall have a maximum area of nine (9) square feet and may not be illuminated.
  - b. A maximum of two (2) off-premises signs shall be permitted. Said off-premises signs may be no greater than four (4) square feet apiece and shall not be illuminated. No such sign shall be allowed in the street right-of-way or within ten (10) feet of a side lot line.

10. Flags. Flags, crests or banners of nations, organizations of nations, states and cities or professional fraternal, religious or civic organizations, except when displayed in connection with commercial promotion. Flag poles may not be taller than the restriction on building height in the applicable zoning district.
11. Garage, estate, yard sale or farm auction. Signs which advertise a private garage or yard sale on the lot on which the sign is located; provided that such signs are displayed no more than twice per year per dwelling unit for a period not to exceed three (3) days. Neighborhood garage sale signs may be located at the entrances to the neighborhood but must not be displayed more than twice per year for a period not to exceed three (3) days.
12. Hazards. Temporary or permanent signs erected by the Town, public utility companies, oil and gas companies or construction companies to warn of danger or hazardous conditions, including signs indicating the presence of underground cables, gas lines and similar devices.
13. Memorial. Memorial signs, plaques or grave markers which are noncommercial in nature.
14. Merchandise. Merchandise, pictures or models of products or services which are incorporated as an integral part of a window display.
15. Notice boards. Notice boards for public or religious institutions or other uses as approved by Town staff and primarily intended for pedestrians.
16. Oil and gas operation. Identification signs for any oil and gas operation.
17. Political. Political signs displayed on private property in accordance with an official election or signs erected on behalf of candidates for public office, provided that:
  - a. The total area of all such signs on a lot does not exceed sixteen (16) square feet.
  - b. All such signs may be erected no sooner than sixty (60) days in advance of the election for which they were made.
  - c. The signs are removed within seven (7) days after the election for which they were made.
  - d. The property owner upon whose land the sign is placed shall give permission for placement of said signs and will be responsible for violations.
18. Public information. Signs which identify rest rooms or public telephones or provide instructions as required by law or necessity, provided that the sign does not exceed two (2) square feet in area or as approved by Town staff. (This category shall be interpreted to include such signs as "no smoking," "rest rooms," "no solicitors," "self-service" and similar informational signs.)
19. Regulatory signs. Regulatory signs erected on private property, such as "no trespassing" signs, which do not exceed two (2) square feet per face or four (4) square feet in total surface area, limited to four (4) such signs per use or per building, whichever is the greater number.
20. Religious symbols. Religious symbols located on a building or lot used for organized religious services.

21. Sale, lease, rent. Temporary signs used to offer for sale, lease or rent the land or buildings upon which the sign is located, provided that:
  - a. One (1) sign per street frontage advertising real estate ("For Sale," "For Rent," "For Lease" or "For Development") not greater than eight (8) square feet in area in residential districts and thirty-two (32) square feet in area in nonresidential districts may be located on the property being advertised, so long as said sign is located behind the street right-of-way line. If the property so advertised lies on a corner lot or double frontage lot, a second sign may be oriented along the second street so long as the two signs are at least one hundred (100) feet apart as measured by the shortest straight line.
  - b. In addition to the on-site real estate signs, a directional sign may be placed along arterial and/or collector roadways within the Town. All off-site direction signs shall be located on a Town approved sign. The message of said signs shall be limited to the name of the property or development being advertised, an address, a telephone number, a directional arrow, mileage to the subject property and the terms "Lot/Home For Sale," "For Rent," "For Lease," "For Development," etc.
  - c. All such temporary signs shall be removed within seven (7) days after the real estate closing or lease transaction.
  - d. No sign allowed under this subsection shall be lighted.
22. Scoreboards. Scoreboards for athletic fields.
23. Sandwich boards shall be no more than eight (8) square feet per side (sixteen (16) square feet total) and shall only be displayed during business hours and within twenty (20) feet of the business that is being promoted.
  - a. When sandwich boards are placed on sidewalks adjacent to the business, it shall be placed so as to not block the flow of pedestrian traffic.
  - b. When sandwich boards are placed on sidewalks fronting any roadway where parallel parking has been established, such signs shall not be placed and no extension or attachment thereto shall reach into the air space within five (5) feet of any surface where vehicles regularly travel, nor on any improved portion of the driving surface that is within five (5) feet of a painted fog line or lane demarcation.
24. Scoreboards. Scoreboards for athletic fields.
25. Special events. Temporary special event signs for religious, charitable, civic, fraternal or similar nonprofit or not-for-profit organizations, provided that:
  - a. Signs shall be erected no sooner than thirty (30) days prior to and removed no later than seven (7) days after the event.
  - b. No such sign shall exceed thirty-two (32) square feet.
  - c. No such sign shall be illuminated.

- d. All such signs shall be located off the street right-of-way, unless otherwise granted permission for such location by the Town or the Colorado Department of Transportation (CDOT). In no case may any such sign impede the view or travel of any motorists or pedestrians or be attached to any structure (government signs, utility poles, etc.) or landscaping within the right-of-way.
26. Strings of light bulbs. Displays of string lights, provided that:
- a. They are decorative displays which only outline or highlight landscaping or architectural features of a building.
  - b. They are steady burning, clear, noncolored bulb lights. No blinking, flashing, intermittent changes in intensity or rotating shall be permitted.
  - c. They are no greater in intensity than five (5) watts.
  - d. They shall not be placed on or used to outline signs or sign supports.
  - e. They shall not be assembled or arranged to convey messages, words, commercial advertisements, slogans and/or logos.
  - f. They shall not create a safety hazard with respect to placement, location of electrical cords or connection to power supply.
  - g. They shall be placed only on private property.
  - h. They shall be maintained and repaired so that no individual light bulb is inoperative. In the event the bulbs are not maintained or repaired, the string lights may be removed at the expense of the owner after giving notice to the owner pursuant to this Article.
27. Text. No permit shall be required for text or copy changes on conforming or legal nonconforming signs specifically designed to permit changes of the text or copy; provided that no structural changes are made to the sign; and provided further that the name of the business to which the sign belongs is not changed.
28. Time and temperature. Signs displaying time and temperature devices, provided that they are not related to a product.
29. Traffic control. Signs for the control of traffic or other regulatory purposes, including signs for the control of parking on private property, and official messages erected by, or on the authority of, a public officer in the performance of his or her duty.
30. Vacancy and no vacancy. All "vacancy" and "no vacancy" signs, where they are nonilluminated, internally illuminated, indirectly illuminated or directly illuminated signs; provided that the area of the sign does not exceed two and one-half (2½) square feet per face. Also, signs designed to indicate vacancy such as "yes," "no" or "sorry" shall also be exempt under the provisions of this Paragraph if they meet the area requirement.
31. Vehicular for sale signs. Motor vehicle for sale signs; provided that:
- a. There is only one (1) sign per vehicle.

- b. The sign does not exceed two (2) square feet.
  - c. The vehicle is located in either an approved sales lot or on private property with the owner's consent. A property with single family zoning may have one (1) vehicle for sale parked on it. A multi-family property may have up to three (3) vehicles for sale parked on the property. Properties with non-residential zoning may have vehicles for sale parked on the property provided the vehicles are parked in approved parking spaces and meet the requirements of items a. and b. above.
  - d. The vehicle does not violate Chapter 8 of the Frederick Municipal Code.
32. Vehicular signs. Signs displayed on trucks, buses, trailers or other vehicles which are being operated or stored in the normal course of a business, such as signs indicating the name of the owner or business, which are located on moving vans, delivery trucks, rental trucks and trailers and the like; provided that the primary purpose of such vehicles is not for the display of signs; and provided further that they are parked or stored in areas appropriate to their use as vehicles.
33. Vending machine signs. A sign permit shall not be required for vending machine signs, provided that the advertisement upon the vending machine sign is limited to the product vended and the sign does not exceed the dimensional boundaries of the machine to which such sign is affixed.

**Sec. 7.5. Prohibited signs.**

The following signs are inconsistent with the purposes and standards in this Article and are prohibited in all zoning districts.

- 1. Flashing, rotating, blinking or moving signs, animated signs, signs with moving, rotating or flashing lights or signs that create the illusion of movement, except for time and temperature devices.
- 2. Any sign that is erected in such a location as to cause visual obstruction or interference with motor vehicle traffic or traffic-control devices, including any sign that obstructs clear vision in any direction from any street intersection or driveway.
- 3. Mechanical or electrical appurtenances, such as "revolving beacons," that are designed to compel attention.
- 4. Roof signs.
- 5. Any sign other than traffic control signs erected, constructed or maintained within, over or upon the right-of-way of any road or highway, except in the case of a sign for which a permit has been issued in accordance with the requirements of this Article.
- 6. Off-premises advertising signs or any other sign not pertinent and clearly incidental to the permitted use on the property where located, except for political signs and signs permitted in Section 7.9 (Standards for Specific Types of Signs).
- 7. Any sign which interferes with free passage from or obstructs any fire escape, downspout, window, door, stairway, ladder or opening intended as a means of ingress or egress or providing light or air.

8. Any sign located in such a way as to intentionally deny an adjoining property owner visual access to an existing sign.
9. Vehicle-mounted signs, including but not limited to signs painted on or attached to semi-trailers or cargo containers when exhibited on private property adjacent to public rights-of-way for the purpose of advertising the business or services offered on the property. Vehicle-mounted signs used in connection with a special event are exempted from the requirements of this Section during the duration of the special event only. Upon the conclusion of the special event, such signs must be dismantled. For the purposes of this Subsection, the term special event shall mean a parade, circus, fair, carnival, festival, farmers' market or other similar event that is different in character from the customary or usual activities generally associated with the property upon which the special event is to occur.
10. Portable signs or signs not permanently affixed or attached to the ground or to any structure, except for real estate signs attached to posts driven into the ground, window signs, temporary barriers, and sandwich boards.
11. Rotating signs.
12. Searchlights.
13. Signs with optical illusion of movement by means of a design which presents a pattern capable of reversible perspective, giving the illusion of motion.
14. Inflatable freestanding signs or tethered balloons.
15. Fabric signs, flags, pennants or banners when used for commercial advertising purposes, except as permitted in Section 7.9 (Standards for Specific Types of Signs).
16. Wind signs.
17. Any sign (together with its supporting structure) now or hereafter existing which, ninety (90) days or more after the premises have been vacated, advertises an activity, business, product or service no longer produced or conducted upon the premises upon which such sign is located. If the sign or sign structure is covered or the identifying symbols or letters removed, an extension of time may be granted by the Building Official upon good cause for such extension being shown. (This provision shall not apply to permanent signs accessory to businesses which are open only on a seasonal basis, provided that there is clear intent to continue operation of the business).
18. Any sign or sign structure which:
  - a. Is structurally unsafe;
  - b. Constitutes a hazard to safety or health by reason of inadequate maintenance or dilapidation;
  - c. Is not kept in good repair; or
  - d. Is capable of causing electrical shock to persons likely to come in contact with it.
19. Any sign or sign structure which:

- a. In any other way obstructs the view of, may be confused with or purports to be an official traffic sign, signal or device or any other official sign;
- b. Uses any words, phrases, symbols or characters implying the existence of danger or the need for stopping or maneuvering a motor vehicle;
- c. Creates in any other way an unsafe distraction for motor vehicle operators; or
- d. Obstructs the view of motor vehicle operators entering a public roadway from any parking area, service drive, private driveway, alley or other thoroughfare.

**Sec. 7.6. Measurement of sign area and height.**

- 1. Sign surface area. The area of a geometric shape enclosing any message, logo, symbol, name, photograph or display face shall be measured using standard mathematical formulas. Time and temperature devices shall not be included within the measurement of maximum sign area.

**Figure 7-1  
Sign Surface Area Measurement**

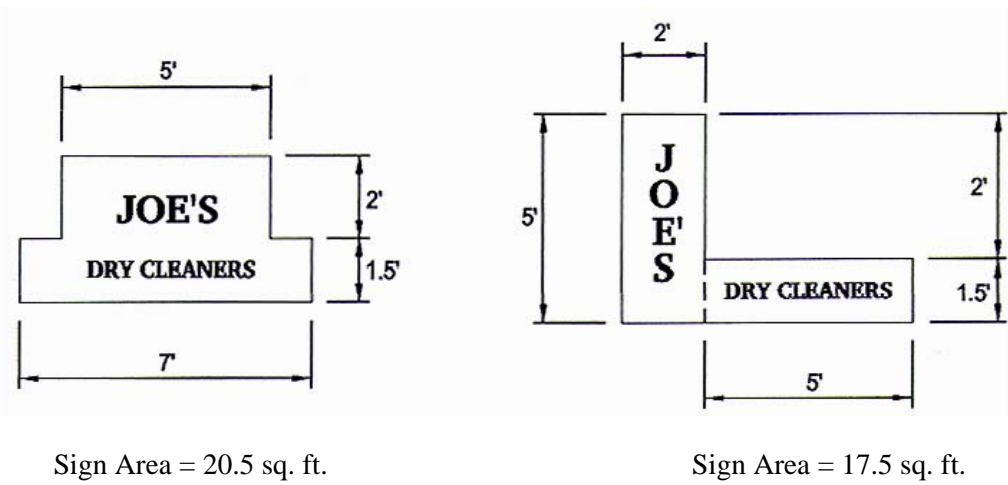

- 2. Sign support. Supporting framework or bracing that is clearly incidental to the display itself shall not be computed as sign area.
- 3. Back-to-back (double-faced) signs. Back-to-back signs shall be regarded as a single sign only if mounted on a single structure and the distance between each sign face does not exceed two (2) feet at any point.
- 4. Three-dimensional signs. Where a sign consists of one (1) or more three-dimensional objects (i.e., balls, cubes, clusters of objects, sculpture), the sign area shall be measured as their maximum projection upon a vertical plane. Signs with three-dimensional objects that exceed a projection of six (6) inches from the sign face may be approved in compliance with Section 7.11.
- 5. Wall signs. If a sign is attached to a wall, only that portion of the wall onto which the sign face or letters are placed shall be calculated in the sign area.

6. Sign height. The height of a sign shall be measured from the highest point of a sign to the ground surface beneath it. When berms are used in conjunction with signage, the height of the sign shall be measured from the mean elevation of the fronting street.
7. Approved sign wall area. The approved sign wall area means any one of the following:
  - a. For a building containing one use, any exterior wall facing an abutting publicly dedicated street or alley or any exterior wall facing a customer parking lot of the use;
  - b. For a building containing two or more uses:
    - (1) Any exterior wall of one individual use that has a primary public entrance and/or exit; and
    - (2) Any exterior wall of one individual use that faces an abutting publicly dedicated street, alley, or the customer parking lot of the building.
  - c. Any substantial difference in the building plan on the façade of the building is considered a separate approved wall area. A “substantial difference” means portions of the building façade that are at 45 degree angles (or greater) to each other.

#### **Sec. 7.7. Sign design.**

1. Design compatibility.
  - a. Creative design encouraged. Signs shall make a positive contribution to the general appearance of the street and commercial area in which they are located. A well-designed sign can be a major asset to a building. The Town encourages imaginative and innovative sign design.
  - b. Professional. Signs shall be made by a professional sign company or other qualified entity.
  - c. Proportionate size and scale. The scale of signs shall be appropriate for the building on which they are placed and the area in which they are located. Building signs shall be harmonious in scale and proportion with the building facade they are mounted to.
  - d. Sign location and placement.
    - (1) Visibility. Signs shall not visually overpower or obscure architectural features.
    - (2) Integrate signs with the building and landscaping. Carefully coordinate the sign with the architectural design, overall color scheme and landscaping. Signs shall be designed to complement or enhance the other signs for a building.
    - (3) Unified sign band. Whenever possible, signs located on buildings with the same block face shall be placed at the same height, in order to create a unified sign band. Locate wall signs at the first floor level only for retail uses.
    - (4) Monument signs. Locate monument signs in a planter setting within a landscaped area at the primary entries to residential, commercial and industrial subdivisions to provide an overall project identity.
    - (5) Pedestrian-oriented signs. Pedestrian-oriented signs are encouraged. It is desirable to include a pedestrian-oriented sign as one (1) of the permitted signs for a business. These signs are designed for and directed toward pedestrians so the pedestrians can easily and comfortably read the sign as they stand adjacent to the business.

- (6) Road right-of-way. No sign shall be erected within the road right-of-way or near the intersection of any roads or driveways in such a manner as to obstruct free and clear vision of motorists or pedestrians, or at any location where, by reason of the position, shape or color, it may interfere with, obstruct the view of or be confused with any authorized traffic sign, signal or device. Signs located at an intersection must be outside of the sight distance triangle (for information on the sight distance triangle, please refer to the Town of Frederick Design Standards and Construction Specifications).
      - e. Landscaping. Freestanding signs shall be landscaped at their base in a way harmonious with the landscape concept for the whole site. Landscaping shall form an attractive, dense cluster at the base of the sign that is equally attractive in winter and summer.
      - f. Reduce sign impact. Because residential and commercial uses generally exist in close proximity, signs shall be designed and located so that they have little or no impact on adjacent residential neighborhoods. Small-scale signs are encouraged.
2. Color.
  - a. Select colors carefully. Colors shall be selected to contribute to legibility and design integrity. Sign colors shall complement the colors used on the structures and the project as a whole. Colors or combinations of colors that are harsh and disrupt the visual harmony and order of the street are unacceptable.
  - b. Use contrasting colors. Provide a substantial contrast between the color and the material of the background and the letters or symbols to make the sign easier to read during both the day and night. Light letters on a dark background or dark letters on a light background are most legible.
  - c. Avoid using too many colors. Colors or color combinations that interfere with legibility of the sign copy or that interfere with viewer identification of other signs shall be avoided.
3. Materials. Signs shall be constructed of durable, high quality architectural materials. The sign package must use materials, colors and designs that are compatible with the building facade. Sign materials must be of proven durability. Treated wood, painted metal, stone, brick and stucco are the preferred materials for signs.
4. Legibility.
  - a. Signs shall be adequately legible under the circumstances in which they are primarily seen. The legibility of signs is related to:
    - (1) The speed at which they are viewed;
    - (2) The context and surroundings in which they are seen; and
    - (3) The design, colors and contrast of the sign copy and sign face.
  - b. The design of the sign, including copy, lettering size and style, and colors, shall logically relate to the average speed of the traffic which will see it. Signs shall legibly convey their messages without being distracting or unsafe to motorists reading them. Symbols and logos can be used in place of words whenever appropriate.

5. Sign illumination.

- a. Use illumination only if necessary.
- b. Sign illumination shall complement, not overpower, the overall composition of the site.
- c. Use a direct light source. All lighted signs shall have their lighting directed in such a manner as to illuminate only the face of the sign. When external light sources are directed at the sign surface, the light source must be concealed from pedestrians' and motorists' "lines of sight."
- d. Signs must be illuminated in a way that does not cause glare onto the street and adjacent properties. Signs shall be lighted only to the minimum level for nighttime readability.
- e. All lighted signs shall meet all applicable electrical codes and the electrical components used shall bear the label of an approval agency. Additionally, electrical permits shall be obtained for electric signs.
- f. Flashing, moving, blinking, chasing or other animation effects shall be prohibited on all signs except time and temperature signs. Signs with a changeable message shall remain motionless for periods not less than one (1) minute. (Ord. 810 §7.7(e)(6), 2005)
- g. Neon tubing is an acceptable method of sign illumination for window signs in commercial districts.
- h. The use of individually cut, back-lit letter signs is encouraged.
- i. No commercial sign within five hundred (500) linear feet of a preexisting residential structure may be illuminated between the hours of 11:00 p.m. and 6:00 a.m. A residence shall be deemed preexisting for purposes of this Section if it has a valid building permit in effect for construction of said structure or if construction of said structure was complete on or prior to the effective date of this Article.

**Sec. 7.8. Sign installation and maintenance.**

1. Installation.

- a. All signs shall be mounted so that the method of installation is concealed.
- b. Projecting signs shall be mounted so they generally align with others in the block.
- c. All signs and all components thereof, including sign structures and sign faces, shall be kept neatly painted, in a good state of repair and in compliance with all building and electrical codes.
- d. Owners of projecting signs extending over public rights-of-way shall be required to maintain public liability insurance in an amount to be determined appropriate by the Town, in which the Town is named as an "other insured."

2. Maintenance.

- a. The owner of a sign and the owner of the premises on which such sign is located shall be jointly and severally liable to maintain such sign, including any illumination sources, in neat and orderly condition and in a good working order at all times, and to prevent the development of any rust, corrosion, rotting or other deterioration in the physical appearance or safety of such sign. The sign must also be in compliance with all building and electrical codes.
- b. The owner of any sign regulated by this Article shall be required to keep signs and supporting hardware, including temporary signs and time/temperature signs, structurally safe, clean, free of visible defects and functioning properly at all times. Repairs to signs shall be equal to or better in quality of materials and design than the original sign.
- c. The Town may inspect any sign governed by this Article and shall have the authority to order the repair, alteration or removal of a sign which constitutes a hazard to safety, health or public welfare by reason of inadequate maintenance, dilapidation or obsolescence.

**Sec. 7.9. Standards for specific types of signs.**

1. Awning signs. An awning sign is a wall sign which is painted, stitched, sewn or stained onto the exterior of an awning. An awning is a movable shelter supported entirely from the exterior wall of a building.

**Figure 7-8  
Sign Types**

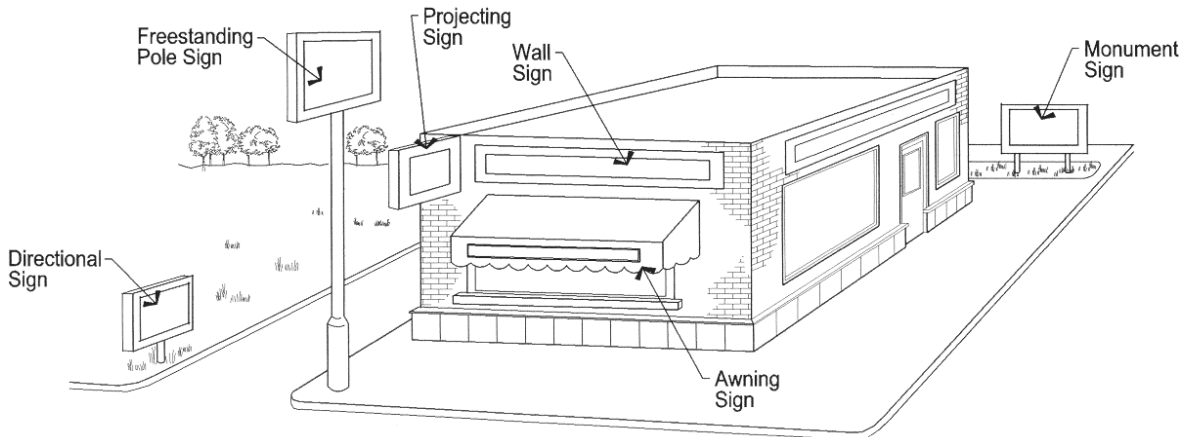

- a. Location. Signs may be placed only on awnings that are located on first- and second-story building frontages, including those fronting a parking lot or pedestrian way. No awning sign shall project beyond, above or below the face of an awning.
  - b. Lighting. Lighting directed downwards that does not illuminate the awning is allowed.
2. Banners. Banners are signs applied to paper, plastic or fabric used to decorate or attract attention to a business establishment. Banners are permitted provided that one of the following events is occurring:
    - a. The signs are displayed in conjunction with a grand opening celebration for a period not to exceed thirty (30) days.

- b. The signs are displayed in conjunction with a special sale for a period not to exceed thirty (30) days. This requirement does not apply if the banner is displayed for less than 24 hours and the banner is less than 10 square feet in size.
- c. The signs are displayed in conjunction with a special event as defined in Section 7.4.

If one of the above events is occurring, then the following regulations apply:

- (1) The signs are displayed no more than two (2) times per calendar year per establishment.
- (2) The banner shall be securely attached to the wall of the establishment, freestanding signs or light poles on private property.
- (3) One (1) banner per street frontage per establishment shall be permitted

d. Banner size.

- (1) The size of the banner is restricted based on the dimensions outlined in Tables 7-1 and 7-2A and B found in Section 7-10.
  - (a) Signs attached to the side of a building shall meet the wall sign dimensions.
  - (b) Any banner not attached to the building (attached to freestanding posts including light posts) shall meet the freestanding sign dimensions.
  - (c) Special event signs shall following the requirements outlined in Section 7.4.

3. Canopy signs. A canopy sign is a wall sign that is permanently affixed to a roofed shelter attached to and supported by a building, by columns extending from the ground or by a combination of a building and columns.

**Figure 7-9  
Canopy and Window Signs**

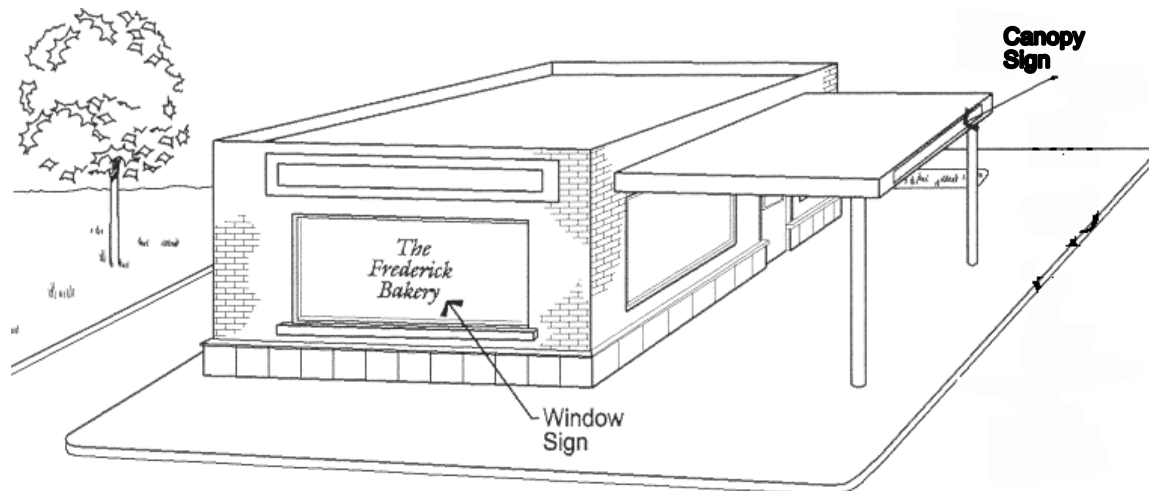

- a. No canopy, with or without signage, shall extend above the roof line of any building. No canopy sign shall project above the top of the canopy upon which it is mounted. However, such signs may project horizontally from the face of a canopy the distance necessary to accommodate the letter thickness and required electrical equipment, but not more than twelve (12) inches (measured from the bottom of the sign). Under-canopy

signs which are perpendicular to the face of the building shall be deemed to be projecting wall signs. Under-canopy signs which are parallel to the face of the building shall be a minimum of eight (8) feet above grade and shall be deemed to be flush wall signs.

4. Electronic Message Center Signs. A message center sign is an electronic sign that allows advertisement of an electronic message.
  - a. Maximum area. The sign shall comply with the height and area requirements established in Section 7.10 (Sign Standards by Zoning District); however, no more than sixty-five percent (65%) of the overall face of the sign will be electronic.
  - b. Maximum number. Only one (1) electronic message center sign will be permitted on site.
  - c. Change of Display of Electronic Messages. Messages on the electronic message board shall not change more frequently than once every one (1) minute.
  - d. Prohibitions. No electronic message centers may contain any flashing, rotating, animated, or otherwise moving features.
5. Freestanding signs. A freestanding sign is a sign which is supported by two (2) or more columns, uprights, poles or braces extended from the ground or which is erected on the ground, but does not include a sign attached to a structure.
  - a. Location. The sign may be located only on a site frontage adjoining a public street. No freestanding sign in any zoning district can be erected closer than eight (8) feet from any curblin, nor closer than four (4) feet to any building. No freestanding signs in business and industrial districts may be located less than twenty-five (25) feet from any property line adjacent to a residential zoning district line.
  - b. Sign mounting. The sign shall be mounted on two (2) or more posts or have a solid monument-type base. Posts shall be concealed in materials architecturally compatible with the buildings on site.
  - c. Landscaping requirements. Landscaping shall be provided at the base of the supporting structure equal to twice the area of one (1) face of the sign. For example, twenty (20) square feet of sign area equals forty (40) square feet of landscaped area.
6. Individual Business/Use Signs.
  - a. No individual use in a multiple use building or development is allowed a separate freestanding sign.
  - b. The total sign area allowed for all signs on a multiple-use building is equal to one (1) square foot of sign per linear foot of approved wall area for all approved wall areas. Uses in multi-use structures are permitted a maximum of two wall signs or one wall sign and one projection sign (commercial districts only), one per approved wall area. Approved wall area is based on the length of the exterior wall of an individual use. Alternately, in instances where a building contains a use or uses not having an exterior wall allowed sign area for all uses in the building may be calculated on a floor area basis. Each business or use is permitted one wall sign, with the allowed sign area on an approved wall area of the building the same proportion as the floor area of the use to the total building floor area.

7. Off-premises signs. Off-premises signs, also known as off-site signs, are generally prohibited, except for those specific types of signs listed in this Section.

- a. Business district identification signs. A business district identification sign is an off-premises sign for the identification of a specific business improvement or redevelopment area approved by the Board of Trustees. Business district signs shall not:
- (1) Interfere with pedestrian or vehicular safety;
  - (2) Detract from the pedestrian quality of the surrounding area; or
  - (3) Add to an over-proliferation of signs on one (1) property or in an area.

The owner of the sign shall enter into an agreement with the Town for funding the ongoing cleaning, maintenance and repair of the sign.

- b. Church and civic club off-premises signs. A church or civic club off-premises sign is an off-premises sign intended to direct people to the church or civic club and/or state meeting dates and times. Such signs shall not:
- (1) Interfere with pedestrian or vehicular safety;
  - (2) Detract from the pedestrian quality of the surrounding area;
  - (3) Add to an over-proliferation of signs on one (1) property or in an area;
  - (4) Be allowed for any organization that has not proven "nonprofit" status;
  - (5) Measure more than four (4) square feet; or
  - (6) Number more than five (5) for any organization.

The owner of the sign shall be responsible for repair and maintenance of the sign.

- c. Directional signs. The Town may work with a private company to provide directional signs to developments currently under way. A directional sign may be placed along arterial and/or collector roadways within the Town. All off-site direction signs shall be located on a Town approved sign. The message of said signs shall be limited to the name of the property or development being advertised, an address, a telephone number, a directional arrow, mileage to the subject property and the terms "Lot/Home For Sale," "For Rent," "For Lease," "For Development," etc.

8. Projecting signs. A projecting sign is any sign supported by a building wall and projecting at least twelve (12) inches or more horizontally beyond the surface of the building to which the sign is attached.

- a. Location. Projecting signs shall be placed only on a ground floor facade, except for businesses located above the ground level with direct exterior pedestrian access. Projecting signs shall be mounted so they generally align with others in the block. This helps to create a "canopy line" that gives scale to the sidewalk.

9. Time and/or temperature signs. A time and/or temperature sign is any sign intended to be displayed for a limited period of time and capable of being viewed from any public right-of-way, parking area or neighboring property.

- a. Maximum area. Time and/or temperature signs which do not exceed ten (10) square feet shall not be required to be included in the allowable sign area permitted in Section 7.6; provided, however, that any identification or advertising which is attached to or made part of the same sign structure shall be included in the allowable sign area for the premises.

10. Wall signs. A wall sign is any sign painted on, incorporated in or affixed to the building wall, or any sign consisting of cut-out letters or devices affixed to the building wall with no background defined on the building wall.
  - a. Location. The sign shall not be placed to obstruct any portion of a window, doorway or other architectural detail. Wall signs shall be located on buildings at the first floor level only for retail uses. No part of a wall sign shall be located more than twenty-five (25) feet above grade level.
  - b. Projection from wall. No sign part, including cut-out letters, may project from the surface upon which it is attached more than required for construction purposes, and in no case more than twelve (12) inches.
  - c. Design. Wall signs shall identify the individual business, building or building complex by name or trademark only.
  
11. Window signs. A window sign is a sign that is painted on, applied or attached to a window or that can be read through the window from the public right-of-way, placed at or below the second floor level.
  - a. Maximum area. When a sign is displayed in a window and is visible beyond the boundaries of the lot upon which the sign is displayed, the total area of such sign shall not exceed:
    - (1) Twenty -five percent (25%) of the window or door area at the ground floor level;  
and
    - (2) Twenty-five percent (25%) of the total allowable sign area for the premises.
  - b. Lighting. All illuminated window signs shall be included in the total allowable sign area for the premises. Temporary posters announcing or advertising events sponsored by noncommercial organizations shall be exempt from limitations for window signs.

**Sec. 7.10.** Sign standards by zoning district.

1. Residential and agricultural signs. Signs in the R-E, R-1, R-2, R-3, R-MH1, R-MH2, A, and P zoning districts may include and shall be limited to:

<b>Table 7-1 Table of Residential Sign Standards</b>							
<b>Sign Type</b>	<b>Minimum Setback from Right-of-Way (feet)</b>	<b>Maximum Height (feet)</b>	<b>Maximum Size (square feet)</b>	<b>Number of Signs</b>	<b>Sign Separation (feet)</b>	<b>Illuminated Signs Allowed</b>	<b>Sign Located in Landscape Area</b>
<b>Freestanding Sign</b>							
Single Family home, duplex, mobile home	Equal to sign height	4	2	1 per structure		No	Yes
Multi-family or triplex building	Equal to sign height	6	16	1 per structure	100 between signs on separate street frontages	Yes	Yes
Public or quasi-public use	Equal to sign height	8	20	1 per use	100 between signs on separate street frontages	Yes	No
Subdivision entrance	Equal to sign height	6	32	1 per entrance	100 between signs on separate street frontages	Yes	Yes
<b>Wall Sign</b>							
Single Family home, duplex, mobile home		No higher than the eave line of the principal building	2	1 per structure		Yes	
Multi-family or triplex building		No higher than the eave line of the principal building	16	1 per structure		Yes	
Public or quasi-public use		No higher than the eave line of the principal building	20	1 per use		Yes	
<b>Non-residential Use Signs</b>							
	Equal to sign height	5	4 sq. ft.	1 per tenant space		No	Yes

2. Business and commercial signs / C-D, C-N, C-C, C-H52, C-E, BLI, and I Zone Districts. Signs in the C-D, C-N, C-C, C-H52, C-E, BLI, and I zoning districts may include and shall be limited to:

<p align="center"><b>Table 7-2A</b>  <b>Table of Non-Residential Sign Standards</b></p> <p align="center">The information below relates to Freestanding Signs only.            Table 7-2B contains standards for other non-residential signs.</p>							
<b>Sign Type</b>	<b>Minimum Setback from Right-of-Way (feet)</b>	<b>Maximum Height (feet)</b>	<b>Maximum Size (square feet)</b>	<b>Number of Signs</b>	<b>Sign Separation (feet)</b>	<b>Illuminated Signs Allowed</b>	<b>Sign Located in Landscape Area</b>
<b>Freestanding Signs</b>							
Adjacent to a Local or Collector Street	1 if sign height is 6 feet or less, otherwise equal to sign height	6 in C-D 12 in C-N 20 in all other districts	Total building floor area up to 10,000: sign area up to 50  Total building floor area between 10,00 and 25,000: sign area up to 75  Total building floor area over 25,000: sign area up to 100	1 per street frontage	200 between signs on separate street frontages  600 between signs on separate street frontages	Yes	Yes
Adjacent to an Arterial Street	If greater than 7, must be setback at least 25 from property line	25	200	1 per street frontage	200 between signs on separate street frontages  600 between signs on separate street frontages	Yes	Yes
Adjacent to I-25 or Hwy. 52	If greater than 7, must be setback at least 25 from property line	30	300	1 per street frontage	200 between signs on separate street frontages  600 between signs on separate street frontages	Yes	Yes
Monument sign	1 if sign height is 6 feet or less, otherwise equal to sign height	6 in C-D 10 in all others	150	1 per street frontage	200 between signs on separate street frontages	Yes	Yes

**Table 7-2B  
Table of Non-Residential Sign Standards**

The information below relates to all non-residential signs other than Freestanding Signs.  
Table 7-2A contains standards for Freestanding Signs

<b>Sign Type</b>	<b>Maximum Height (feet)</b>	<b>Maximum Size (square feet)</b>	<b>Number of Signs</b>	<b>Duration</b>	<b>Illuminated Signs Allowed</b>	<b>Maximum Projection (inches)</b>	<b>Location</b>
<b>Wall Sign</b>							
Canopy/ Awning Signs	Minimum 8' above finished grad	.5 per linear foot of awning/canopy	1 per building tenant	Permanent	Yes	Stitched to or incorporated into awning; may not be riveted or otherwise fastened to awning	Approved wall area
Information Sign	6	5	2	Permanent	Yes	15	Approved wall area
Wall Sign	Single use building: 20 or top of wall, whichever is less  Multiple use building: 20 or below 2 <sup>nd</sup> story floor, whichever is less	Single use building: 32 or 1 per linear foot of approved wall area  Multiple use building: 1 per linear foot of approved wall area of tenant space or based on total building floor area (see Section 7.6.7)	1 per approved wall area	Permanent	Yes	15	Approved wall area
Window Sign	20 or top of window, whichever is less	25% of window area	1 per window	Permanent or temporary	Yes	None	Approved wall area